

# **CNH**

**Original Parts**

**INSTALLATION  
INSTRUCTIONS**

**#710660046 ALL WEATHER CAB**

**COMPACT TRACTOR**

**NEW HOLLAND MODEL  
TC30**

**ONE ONLY VINYL ENCLOSURE CAB**  
**Catalog # 710660046**  
**FOR NEW HOLLAND TC 30 Tractor**

CARTON CONTENTS

Key#	Part#	Qty	Description
1	11203	1	Foot, RH
2	11204	1	Foot, LH
3	11207	2	Lower Foot Pocket Guard
4	11208	2	Upper foot Pocket Guard
5	11209	1	Front Panel Cross Bar
6	11201	1	Rear Post Bracket, RH
7	11202	1	Rear Post Bracket, LH
8	10926	2	Front Post
9	40062	1	Rear Post, RH
10	40063	1	Rear Post, LH
11	11217	1	Rear Boxing Post, RH
12	11206	1	Rear Boxing Post, LH
13	11199	1	Roll Bar Bracket, RH
14	11200	1	Roll Bar Bracket, LH
15	10001	1	Top Frame
16	11213	1	Front Panel Vinyl
17	11214	1	Rear Curtain
18	11215	1	Door, RH
19	11216	1	Door, LH
20	11210	1	Door Bottom, RH
21	11211	1	Door Bottom, LH
22	10120	1	Safety Glass Windshield
23	10000	1	ABS Plastic Top
24	9820	1	Door Hardware Package
25	10121	1	Hand Operated Windshield Wiper
26	11212	1	Hardware Package (contents listed below)
	786	11	1/4"-20 x 5/8" Cap Screw
	788	5	1/4"-20 x 3/4" Cap Screw
	5144	2	1/4"-20 x 2 3/4" Cap Screw
	1514	8	1/4" Flat Washer
	730	18	1/4"-20 Two Way Lock Nut
	784	6	5/16"-18 x 3/4" Cap Screw
	317	6	5/16" Flat Washer
	7	2	5/16" Lock Washer
	729	6	5/16"-18 Two Way Lock Nut
	8220	2	M8-1.25 x 20 Cap Screw
	4902	2	Plastic Protectors

Step 1:

Use the parts list and Figure 1 to identify all the steel parts.

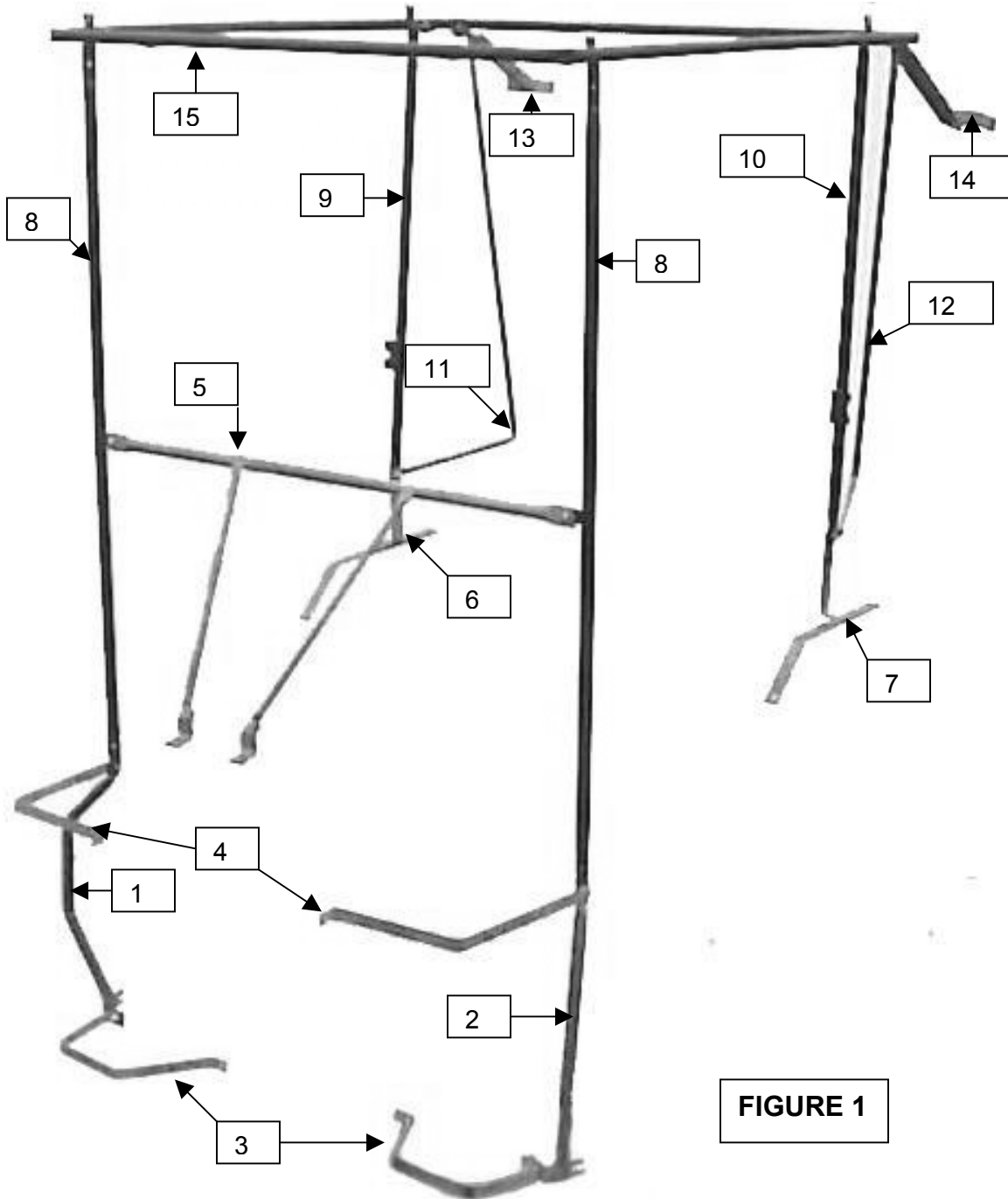

FIGURE 1



# WARNING

This cab is designed to provide foul weather protection only. It does not provide protection from noise, exhaust fumes, chemicals or injury from collision, or other accidents.

1. Do not operate machine in confined areas without proper ventilation
2. Thoroughly check area of operation before using the machine
3. The cab adds height to the machine. Low tree limbs and other overhead structures that did not interfere with the operation of the machine before, may now be obstacles

## MAINTENANCE INSTRUCTIONS

Periodically check all bolts to see that they are tight. If bolts become loose, failure of cab parts may occur.

Door latches and hinges should be lubricated with light machine oil for proper operation.

**DO NOT CLEAN THE CLEAR PLASTIC WINDOWS WHEN THE PLASTIC IS DRY.  
THE CLEAR PLASTIC WILL SCRATCH.**

Avoid contact with plastic windows. Keep plastic windows clean by washing them with clear running water and rubbing with your bare hands, only. The use of a rag, sponge or brush will scratch the plastic. Liquid soap may also be used for window cleaning. During freezing weather, an automotive windshield washer solvent may be used.

Use liquid soap and water to clean colored vinyl portions. Scrubbing with a brush or rag is also permitted on the colored vinyl portions

## STORAGE INSTRUCTIONS

Prior to storage clean the windows and colored vinyl parts with a mild automotive detergent, rinse with clean water and allow to thoroughly dry, Store cab in a clean dry place out of direct sunlight. Avoid folding plastic windows.

**READ THIS MANUAL COMPLETELY BEFORE BEGINNING INSTALLATION.**

- The right side of the machine is determined from the operators seated position.
- The words “bolt” will refer to a 1/4”x5/8” bolt and “nut” will refer to a 1/4” locknut.

## Step 2; See Figure 2:

Install RH Foot (1), LH Foot (2), and Lower Foot Pocket Guards (3).

A. Remove the bolts at reference A. Use an M8 x 20mm cap screw and 5/16" lock washer to secure the outer end of a Foot Pocket Guard and the Foot to the step plate. Secure the inner end of the foot pocket guard to the step plate with a 5/16" x 3/4" cap screw 5/16" lock nut.

B. Mark and drill a 5/16" hole in the center of the notch on the lower end of the Foot. Secure with a 5/16" x 3/4" cap screw, 5/16" flat washer and locknut.

**Note:** If the tractor has a right side step, drilling will not be necessary.

C. Repeat this step on the left side with LH Foot and another Lower Foot Pocket Guard.

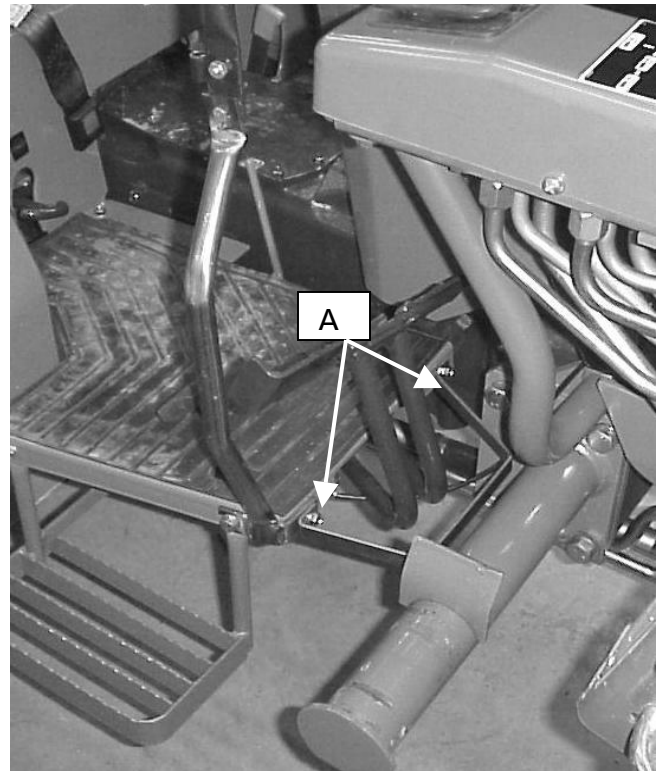

Figure 2

## Step 3; See Figure 3 & 3A:

Install Front Panel Cross Bar (5).

A. Remove the bolts at reference B. Raise the latch plate and place two 1/4" flat washers under each bolt location of the latch. Replace the bolts and tighten securely.

B. Remove the bolts at reference C. Place the welded tabs of the Front Panel Cross Bar over the holes and replace the bolts. Tighten securely.

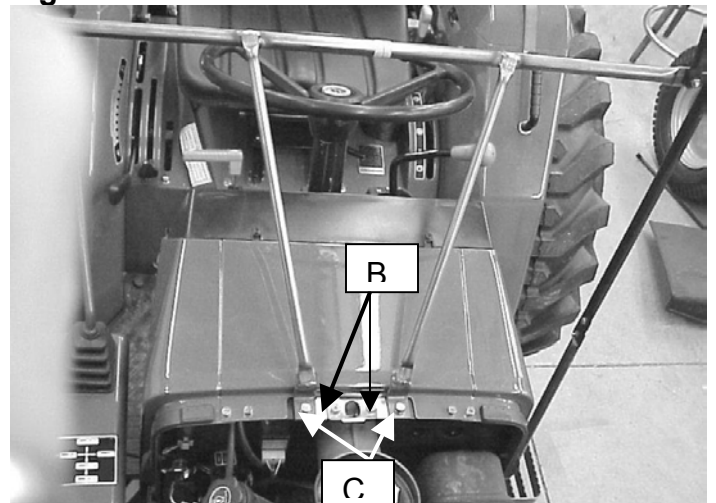

Figure 3



Figure 3A

**Step 4; See Figure 4:**

Install Upper Foot Pocket Guards (4).

A. Remove the bolt at reference D. Place an Upper Foot Pocket Guard over the hole and replace the bolt. Do not tighten at this time.

**Note:** If the cab is to be installed on a tractor with a loader omit the right Upper Foot Pocket Guard.

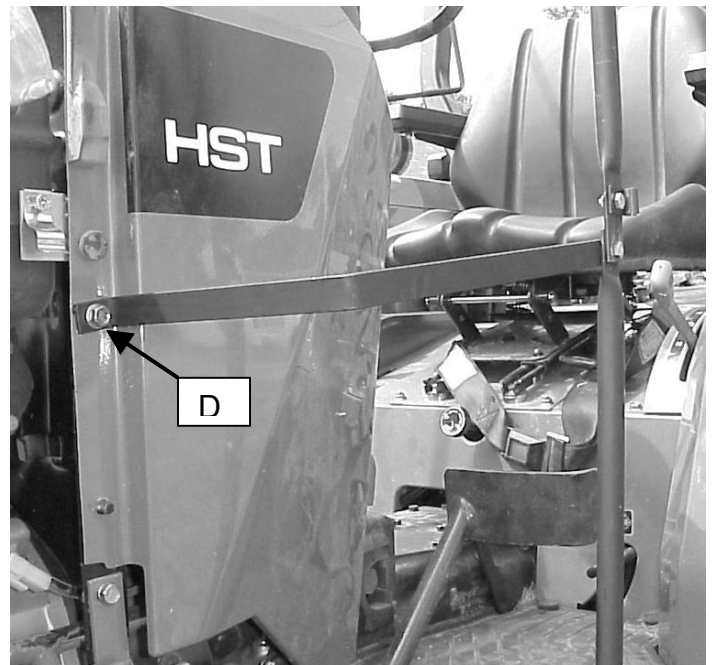

**Figure 4**

**Step 5; See Figure 5:**

Install Front Posts (8).

A. Use two bolts and nuts to secure the Front Posts to the ends of the Front Panel Cross Bar. Do not tighten these bolts at this time.

B. Use two 1/4" x 3/4" bolts and locknuts to attach the bottom ends of the Posts to the Feet and the Upper Foot Pocket Guards. Do not tighten at this time.



**Figure 5**

**Step 6; See Figure 6:**

Install Rear Post Bracket, RH (6) & Rear Post Bracket LH (7).

A. Place the right Bracket on the fender. Insert a 5/16" x 3/4" cap screw down through the bracket and fender. Add a 5/16" flat washer and lock nut. Do not tighten at this time.

B. Align the bracket parallel with the edge of the fender. Mark and drill a 5/16" hole in the fender.

C. Insert a 5/16" x 3/4" cap screw down through the holes and add a 5/16" flat washer and locknut. Tighten both bolts.

**Note:** If the tractor has the handle kit the upper handle hole is used to mount the bracket.



**Figure 6**

**Step 7; See Figure 7:**

Install Rear Post, RH (9), LH (10) & Rear Boxing Post RH (11), LH (12).

A. Insert a 1/4" x 3/4" cap screw outwards through the right Rear Bracket, right Rear Post, and then the right Rear Boxing Post.

B. Add a nut and tighten enough to hold the posts upright.

C. Repeat this step on the left side.

**Note:** The upper tab of the Rear Post should point inward with the latch plate forward



**Figure 7**

**Step 8; See Figure 8:**

Install Roll Bar Bracket, RH (13) & Roll Bar Bracket, LH (14).

- A. Place the clamp of the roll bar bracket over the rops bar and insert a 1/4" x 2 3/4" cap screw Inwards. Add a nut. Do not tighten at this time.
- B. Repeat this step on the left side.



**Figure 8**

**Step 9; See Figure 8 & 9:**

Install Top Frame (15)

- A. Place the top frame onto the bent ends of the posts. Insert two 1/4" x 3/4" cap screws up through the Rear Boxing Posts, the forward ends of the Rops Bracket and then the tabs welded to the rear of the Top Frame. Add nuts. Do not tighten at this time.
- B. Insert four bolts upwards through the Front and Rear Posts. Add nuts do not tighten at this time.
- C. Place a plastic protector over the bent ends of each rear post. (see inset)

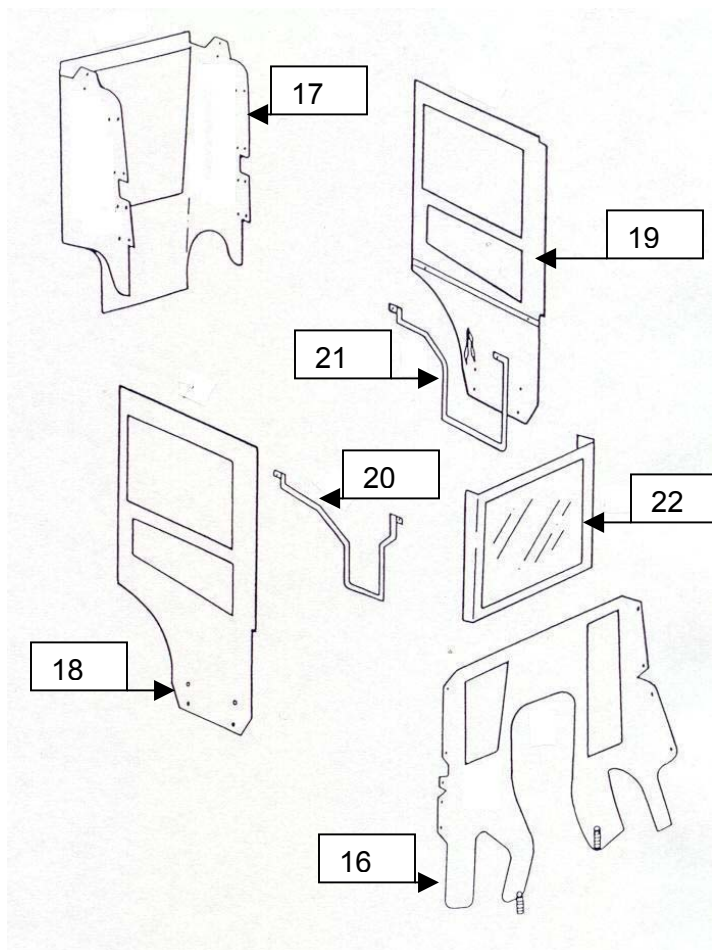

**Figure 9**

**STEP 10; SEE Door Hardware instructions:**  
(located in 9820 Door Hardware Package)

Install the Doors, RH (18) & LH (19) for frame / door alignment.

- A. Follow the instructions in the Door Hardware Package to install the Door Bottoms RH (20), LH (21) and the Door Latches.
- B. Install Doors, do not tighten top hinge bolts, as doors will be removed after alignment.
- C. Close and latch both Doors.
- D. Tighten all framework bolts at this time.
- E. Remove the doors at top hinge.

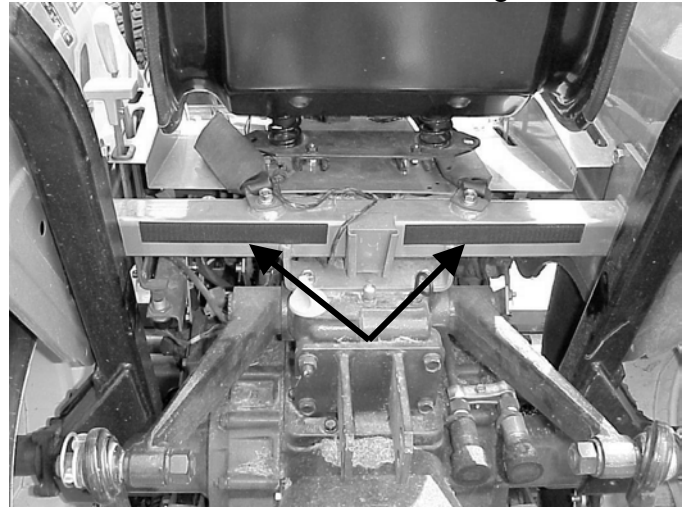

**Figure 11**

**STEP 11; SEE FIGURE 11 & 11A:**

Install Rear Curtain (17).

- A. Lay the rod sewn into the rear curtain over the rear of the top frame. Close the snap flaps at the corners.
- B. Close the snap flaps over the rear posts and brackets.
- C. Secure the adhesive hook and loop fastener to the rear as shown in Figure 11A.



**Figure 11A**

**STEP 12; SEE FIGURE 12:**

Install Windshield (22), Front Panel Vinyl (16) & ABS Plastic Top (23).

A. Lay the rod sewn into the top of the Front Panel Vinyl over the Front Panel Cross Bar. Close the snap flaps around the Front Posts and Feet.

B. Place the Plastic Top onto the Top Frame.

C. Place the lower edge of the Windshield on top of the Front Panel Vinyl and Front panel Cross Bar trapping the vinyl in place.

D. Raise the front of the top and push the windshield back against the frame. Lower the top over the top edge of the windshield trapping it in place.

E. Hook the springs under the step plates being careful to avoid moving parts.

F. Place a 1/4" flat washer onto each of four bolts. Insert the bolts inwards into the Top and Top Frame. Add nuts and tighten.

G. Secure the adhesive hook and loop fastener to the lower dash panel.

H. Reattach the doors.

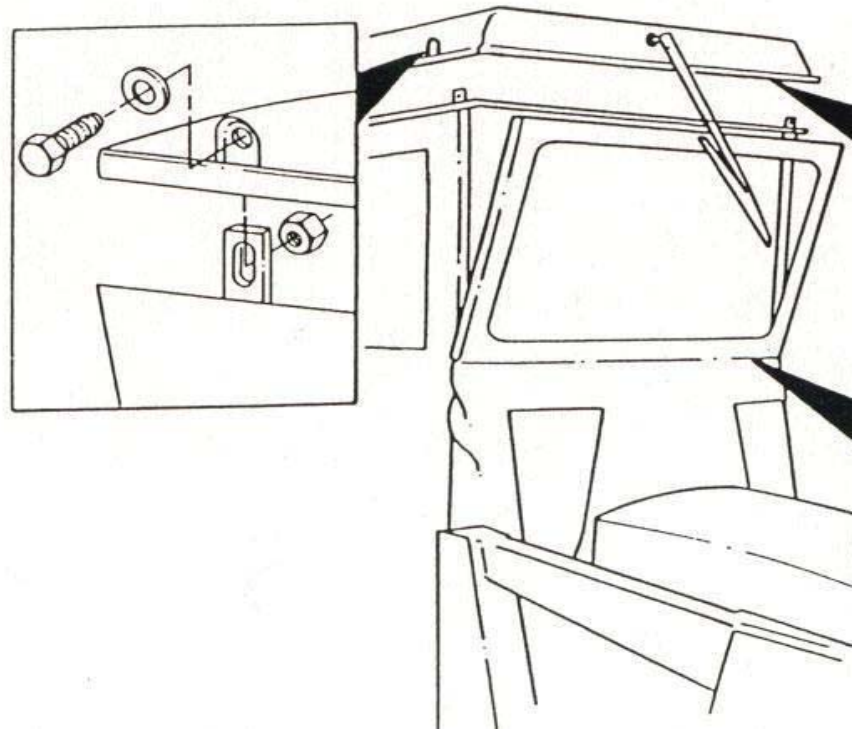

# INSTALL HAND OPERATED WIPER

## CONTENTS

PART#	KEY#	DESCRIPTION
9226		Handle Assembly
	1	Stem
	2	Nut
	3	Washer, Steel
	4	Washer, Rubber
	5	Threaded Body
	6	Handle
5673	7	Wiper Arm
9225	8	14" Wiper Blade

## INSTALLATION

1. Remove the handle from the stem and the stem from threaded body.
2. From inside the cab insert the threaded body through the hole.
3. Place the rubber washer and then the steel washer over the body. Add the nut and tighten.
4. Insert the stem from outside the cab. Place handle on the stem aligning the flat spot on the stem with the set screw. Tighten the setscrew.
5. With the handle hanging straight down attach the wiper arm straight down.
6. Attach the wiper blade to the end of the arm.
7. Adjust the length of the arm by lifting the gray lever under the arm and pulling it out.

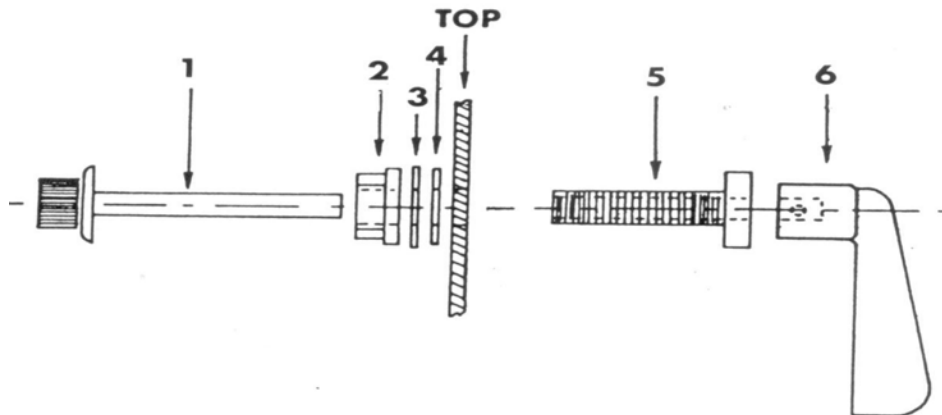

**For Replacement Parts and Accessories Contact:**

**Original Tractor Cab Co., Inc.**

**P.O. Box 97 6849 W. Front St.**

**Arlington, IN 46104**

**Phone 765-663-2214**

**Fax 765-663-2101**

**Email [Sales@originalcab.com](mailto:Sales@originalcab.com)**

**Visit us on the web to see our other products.**

**[www.originalcab.com](http://www.originalcab.com)**

**Cabs for Lawn Tractors, Garden Tractors, Compact Tractors, Snow Blowers, Utility Vehicles**

**Sunshades for Tractors, Mowers, & Utility Vehicles**

**Storage Covers for Lawn and Garden equipment. Bug Screen cab enclosures.**