



CAB #12110
FOR
JOHN DEERE 1 SERIES TRACTORS
With Forward Leaning Roll Bar Only

PARTS LIST – ASSEMBLY INSTRUCTIONS

IMPORTANT !

READ THIS MANUAL CAREFULLY AND KEEP FOR FUTURE REFERENCE

CAUTION !

REMOVE THE VINYL PANELS FOR TRANSPORT IN AN OPEN TRUCK OR TRAILER



**THIS CAB WILL NOT PROTECT OPERATOR FROM INJURIES CAUSED BY ROLLOVER,
COLLISION, OR OTHER ACCIDENTS**



WARNING

This cab is designed to provide foul weather protection only. It does not provide protection from noise, exhaust fumes, chemicals or injury from collision, or other accidents.

1. Do not operate machine in confined areas without proper ventilation
2. Thoroughly check area of operation before using machine
3. The cab adds height to the machine. Low tree limbs and other overhead structures that did not interfere with the operation of the machine before, may now be obstacles

MAINTENANCE INSTRUCTIONS

Periodically check all bolts to see that they are tight. If bolts become loose, failure of cab parts may occur.

Door latches and hinges should be lubricated with light machine oil for proper operation.

**DO NOT CLEAN THE CLEAR PLASTIC WINDOWS WHEN THE PLASTIC IS DRY.
THE CLEAR PLASTIC WILL SCRATCH.**

Avoid contact with plastic windows. Keep plastic windows clean by washing them with clear running water and rubbing with your bare hands, only. The use of a rag, sponge or brush will scratch the plastic. Liquid soap may also be used for window cleaning. During freezing weather, an automotive windshield washer solvent may be used.

Use liquid soap and water to clean colored vinyl portions. Scrubbing with a brush or rag is also permitted on the colored vinyl portions

STORAGE INSTRUCTIONS

Prior to storage clean the windows and colored vinyl parts with a mild automotive detergent, rinse with clean water and allow to thoroughly dry, Store cab in a clean dry place out of direct sunlight. Avoid folding plastic windows.

INSTALLATION

READ THIS MANUAL COMPLETELY BEFORE BEGINNING INSTALLATION.

- **The right side of the machine is determined from the operators seated position.**
- **The words "bolt" will refer to a 1/4"x 5/8" bolt and "lock nut" will refer to a 1/4" locknut unless specified otherwise.**
- **Do not tighten bolts during assembly unless instructed to do so.**
- **Park tractor on level ground, lower attachments to ground, remove start key.**

LIMITED WARRANTY SNOW REMOVAL EQUIPMENT CABS

COVERED BY WARRANTY

ORIGINAL TRACTOR CAB CO., INC., (the "Company") warrants to the owner that each new product listed below is merchantable and free of defects in workmanship and material.

During the warranty period, the dealer from whom the product was bought, or the Company, will provide, free of charge, parts and the shipping costs of parts necessary to correct any defect in workmanship and material.

WARRANTY PERIOD

The company products listed below are warranted for the stated period from the date of the original purchase:

- | | |
|--|--------|
| 1. Cabs for tractors and snow removal equipment | 1 Year |
| 2. Company manufactured accessories for above cabs | 1 Year |
| 3. Sunshades for lawn and garden tractors | 1 Year |
| 4. Repair parts | 1 Year |

OWNER'S RESPONSIBILITIES

The owner of a new Company manufactured product must do the following to qualify for warranty service :

1. Retain the original invoice or other proof of purchase to avoid unnecessary difficulties in determining eligibility for warranty work.
2. Notify the dealer from whom the product was bought, or the company, as soon as possible after discovery of a possible defect, and provide proof of original purchase.
To notify the company write to: Original Tractor Cab Co., Inc., P.O. Box 97, Arlington, IN 46104.
3. The owner may, upon notification by the Company, be required to return the defective part, or parts, to the Company for inspection and warranty service.

NOT COVERED BY WARRANTY

The following are not covered by this warranty:

1. Transportation charges to and from servicing dealer or the Company.
2. New products, which have been, subject to misuse, negligence or accident, or have been altered or repaired in a manner not authorized by the Company.
3. Windshield wipers, lights, or accessories that are warranted separately by their respective manufacturers, except Company agrees to make available to the owner whatever warranty benefits may be made available to the Company by the manufacturers.

All implied warranties, except to the extent prohibited by any applicable law, shall have no greater duration than the warranty period for the applicable product, some states do not allow limitation on how long an implied warranty lasts, so the above limitation may not apply to you.

The Company's' liability arising out of warranties representation, instructions, or defects from any abuse, shall be limited exclusively to repair or replacing parts under the condition in the warranty, and in no event will Company be liable for incidental or consequential damages. Some states do not allow the exclusion or limitation of incidental or consequential damages, so the above limitation or exclusion may not apply to you.

This warranty gives you specific legal rights, and you may also have rights that vary from state to state.

Carton Contents: Cab #12110 for John Deere 1 Series Tractors

Key #	Part #	Qty.	Description
1	11846	1	Foot, RH
2	11847	1	Foot, LH (welded tab)
3	11848	1	Foot Brace, RH
4	11849	1	Foot Pocket Guard
5	12051	1	Foot Brace, LH
6	10926	1	Front Post, Long, RH
7	10852	1	Front Post, Short, LH
8	10010	1	Front Panel Cross Bar
9	10002	1	Top Frame Brace, RH
10	10003	1	Top Frame Brace, LH
11	12052	1	Rear Post Bracket, RH
12	12053	1	Rear Post Bracket, LH
13	11969	2	Vinyl Stay
14	10750	1	Rear Post, RH
15	10751	1	Rear Post, LH
16	11024	2	ROPS Clamp
17	12111	1	ROPS Brace, RH
18	12112	1	ROPS Brace, LH
19	12113	1	Top Frame, (Special Rear Half)
20	10749-B	1	Windshield
21	11856-B	1	Front Panel Vinyl
22	12115-B	1	Rear Curtain
23	11858-B	1	Door, RH
24	11859	1	Door Bottom, RH (Long Tab)
25	11860-B	1	Door, LH
26	11861	1	Door Bottom, LH
27	12114	1	ABS Plastic Top (green) (Notched)
	9820	1	Door Hardware Package
	12116	1	Trim Package (contents listed below)
	12117	2	10" Foam Pad (for rear corners of Top Frame)
	12118	2	10" Edge Trim (for notches in green top)
	12119	1	Hardware Package (contents listed below)
	786	15	1/4"-20 x 5/8" Bolt
	788	6	1/4"-20 x 3/4" Bolt
	929	2	1/4"-20 x 3" Bolt
	730	23	1/4"-20 Two Way Lock Nut
	1514	4	1/4" Flat Washer
	784	1	5/16"-18 x 3/4" Cap Screw
	9842	1	5/16" Flange Lock Nut
	60472	2	M8 - 1.25 x 65mm
	4902	2	Plastic Cover Notched
	9829	2	Plastic Cover

Tools Required: 7/16" Socket & Wrench, 1/2" Socket and Wrench, Mallet, 13 & 15mm Socket & Wrench, Needle Nose Pliers & 3/32" Allen Wrench

Step 1; See Figure 1:

Use the parts list and Figure 1 to identify the steel parts.

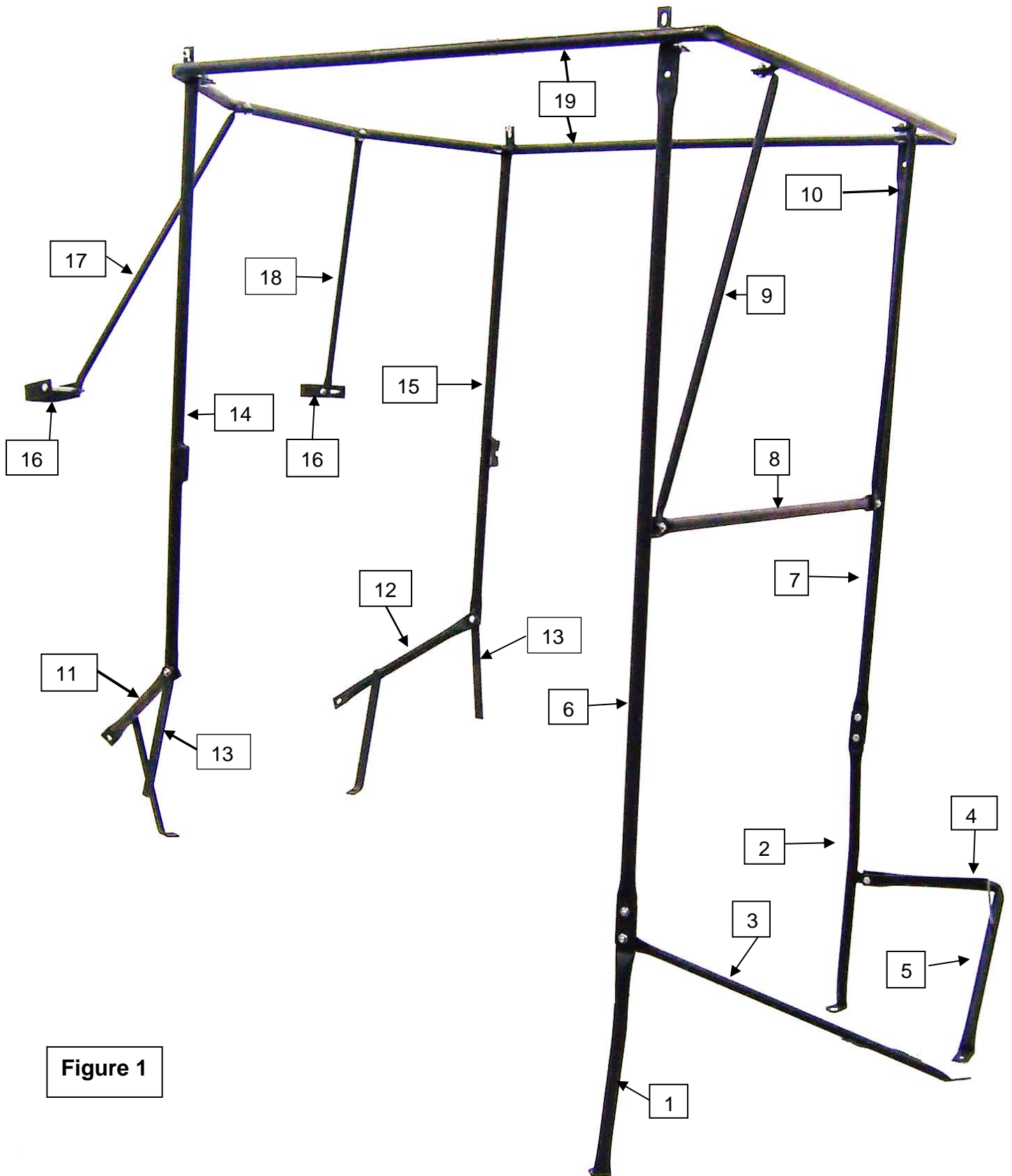

Figure 1

Step 2; See Figure 2:

Reposition the loader control lever.

- A. Pull the rubber boot up out of the way.
- B. Loosen the locknut at the base of the lever and turn the lever so that it is leaning inward.
- C. Tighten the locknut and replace the boot.

Step 3; See Figure 3:

Remove fender lights (on some models).

- A. Unplug the light. Remove the bolt that holds the light in place and remove it from the fender.

Step 4; See Figure 4:

Relocate the SMV Bracket (on some models).

- A. Remove the caution light bolts and then remove the black SMV bracket from the ROPS. Replace the light bolts and tighten. Do not overtighten.
- B. Remove the silver SMV holder from the black SMV bracket. Use two M8 x 65mm bolts from the cab hardware and the two M8 nuts from the SMV holder to attach the holder to the two holes in the ROPS below the lights.



Figure 2



Figure 3

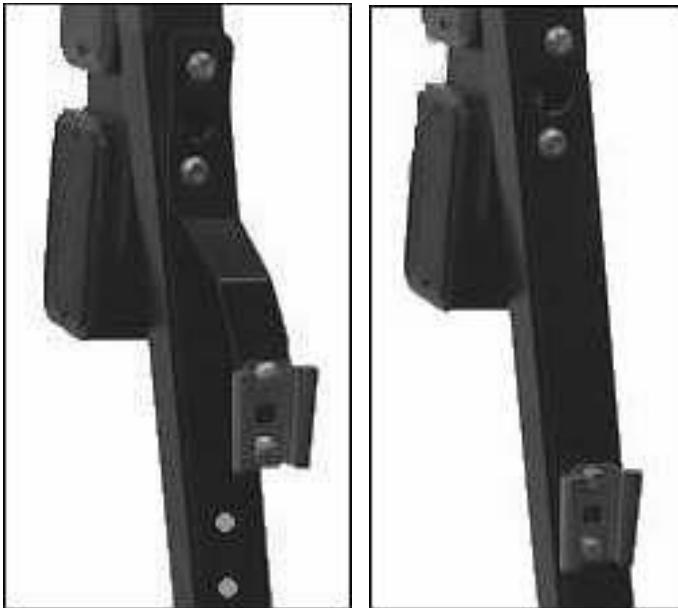

Figure 4

Step 5; See Figure 5:

Install right Foot (1) and right Foot Brace (3).

A. Remove the bolt in the step plate at Reference A.

B. Place the right Foot over the washer and hole. Replace the bolt, turn the bolt in far enough to keep the foot in position. **Do not tighten at this time.**

C. Insert a 5/16" x 3/4" bolt down through the large hole in the Brace and then the unused hole in the motor mount. Add a 5/16" flange lock nut to attach the Brace to the motor mount as shown. **Do not tighten at this time.**

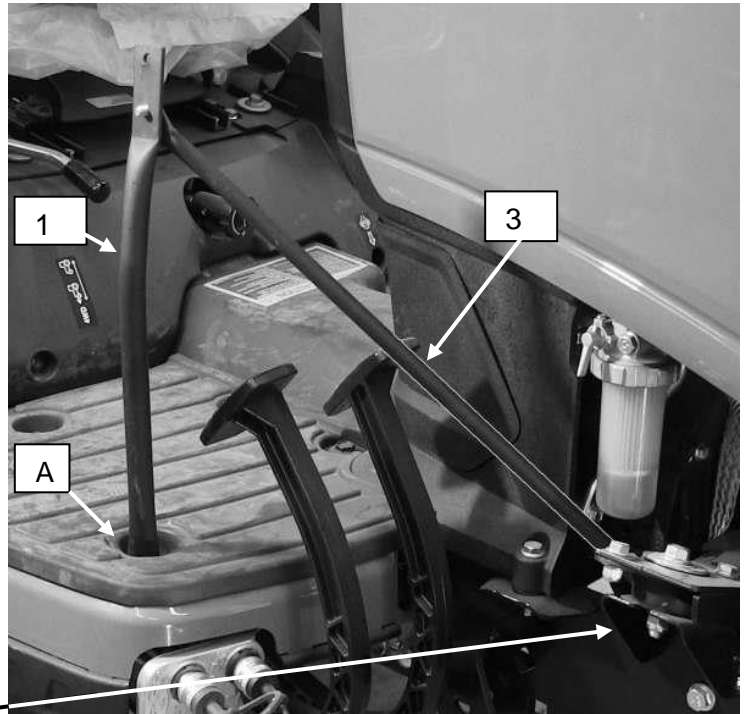
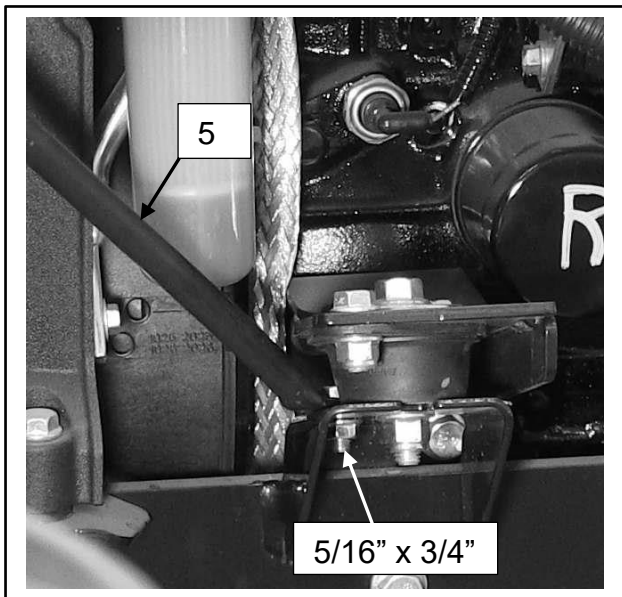

Figure 5



Step 6; See Figure 6:

Install left Foot (2), Foot Pocket Guard (4) and left Foot Brace (5).

A. Remove the nut only at Reference C. Place the large hole of the Foot Brace under the bolt and replace the nut. **Do not tighten at this time.**

B. Remove the bolt at reference B. Place the left Foot over the washer and hole. Replace the bolt, turn the bolt in far enough to keep the foot in position. **Do not tighten at this time.**

C. Place the Foot Pocket Guard in position as shown. Insert a 1/4" x 3/4" bolt out through the holes. Place the small hole of the Foot Brace over the bolt. Add a nut. **Do not tighten at this time.**

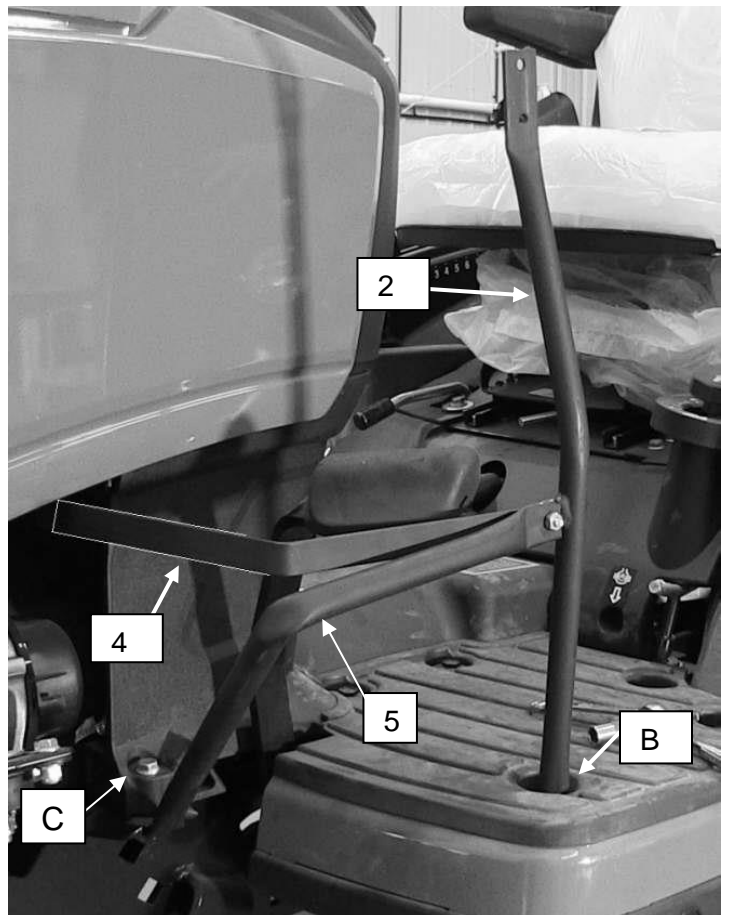

Figure 6

Step 7; See Figure 7:

Install Front Post right (long) and left (short) (6 & 7).

A. Insert a 1/4" x 3/4" bolt outwards through the hole in the Foot Brace, the lower hole in the foot and the post. **Add a locknut, do not tighten at this time.**

B. Insert a bolt outward through the upper hole in the foot and the post. Place a hinge from the door hardware package over the bolt and add a locknut. **Do not tighten at this time.**

C. Repeat on left side of tractor using two bolts.

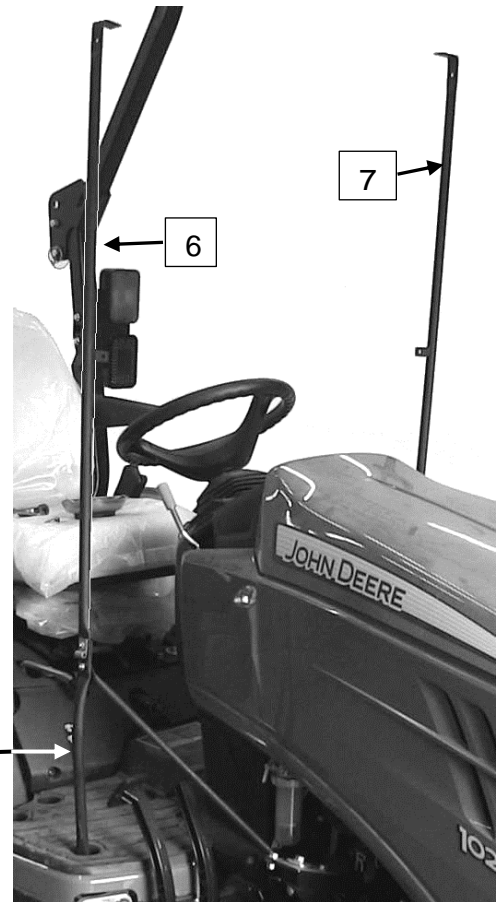

Figure 7

Step 8; See Figure 8:

Install Top Frame Braces (9 & 10) and Front Panel Cross Bar (8)

Note: If you are installing the optional safety glass windshield omit Top Frame Braces.

Note: Bent ends of Top Frame Braces will point rearwards and lay flat when properly installed.

A. Insert a 1/4" x 3/4" bolt forward through the tab on the post, the end of the Front Panel Cross Bar and then the lower end of the right Top Frame Brace. Tighten just enough to hold the brace up.

B. Repeat on left side of tractor.

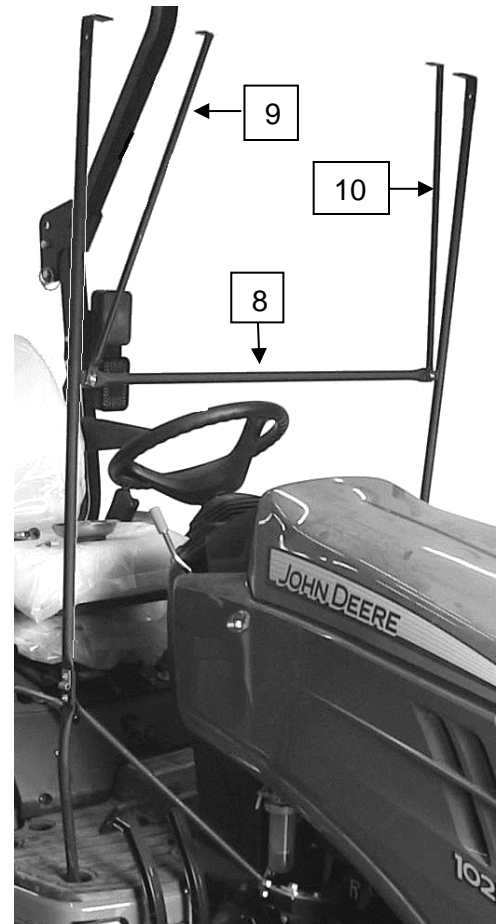

Figure 8

Step 9; See Figure 9:

Install the right and left Rear Post Brackets (11 & 12).

- A. Remove the bolts at Reference D.
- B. Place the bracket on the tractor as shown.
- C. Reinstall the bolts through the bracket holes.
Do not tighten at this time.
- D. Repeat the above steps on the left side.

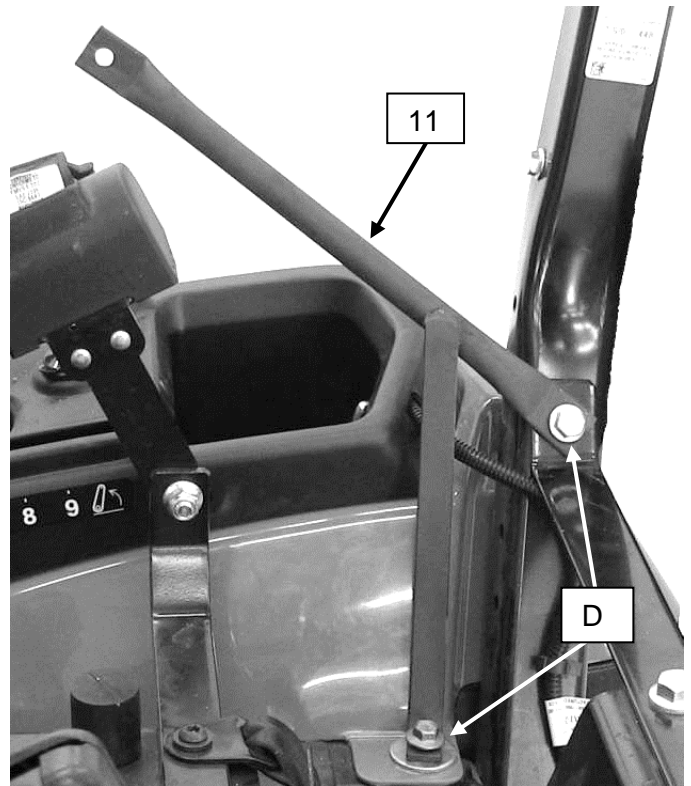

Figure 9

Step 10; See Figure 10:

Install right & left Rear Posts (14 & 15), and the Vinyl Stays (13).

NOTE: When Rear Posts are properly installed, latch plates will be to the front with the notch to the outside of the enclosure.

- A. Insert a 1/4" x 3/4" bolt outwards through the Rear Post Bracket the right Rear Post and then a Vinyl Stay. Add a nut. Tighten enough to keep the parts upright.
- B. Repeat step 10A on the left side with left Post and another Vinyl Stay.

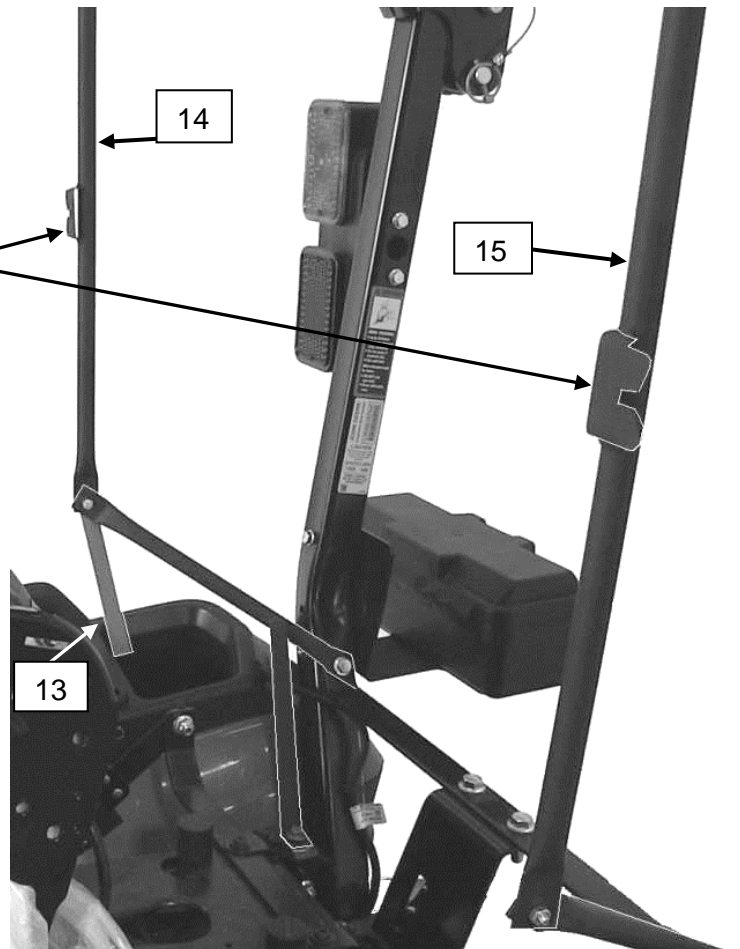

Figure 10

Step 11; See Figure 11:

Install right & left ROPS Braces (17 & 18), and the ROPS Clamps (16).

A. Place a ROPS Clamp over the ROPS as shown. Insert a 1/4" x 3" bolt inwards through the clamp and then the right ROPS Brace. Add a nut. **Do not tighten at this time.**

B. Repeat step 11A on the left side with left ROPS brace and the left ROPS Bracket.

Step 12; See Figure 12:

Install Top Frame (19).

A. Place the Top Frame onto the bent ends of the Posts, ROPS Braces and Top Frame Braces.

B. Insert eight bolts up through the Rear Posts, the Front Posts, the Top Frame Braces and the ROPS Braces. Add nuts. **Do not tighten at this time.**

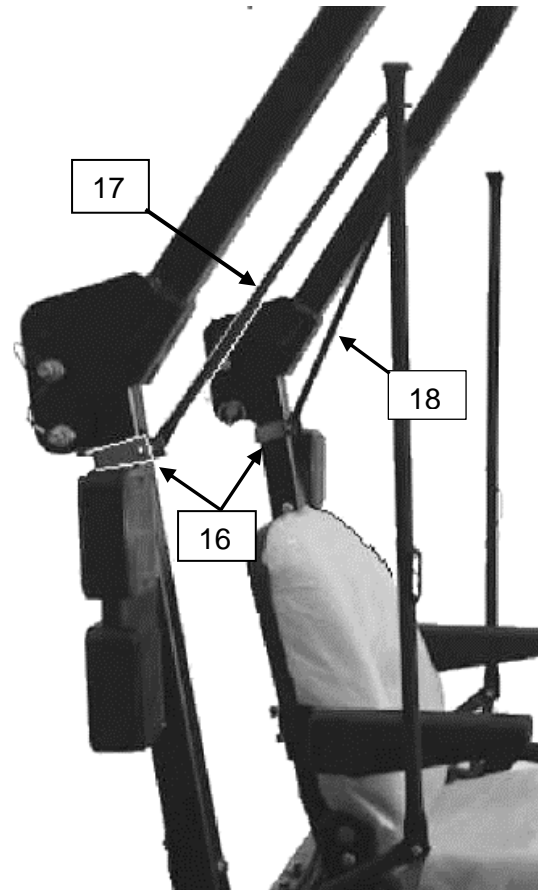

Figure 11

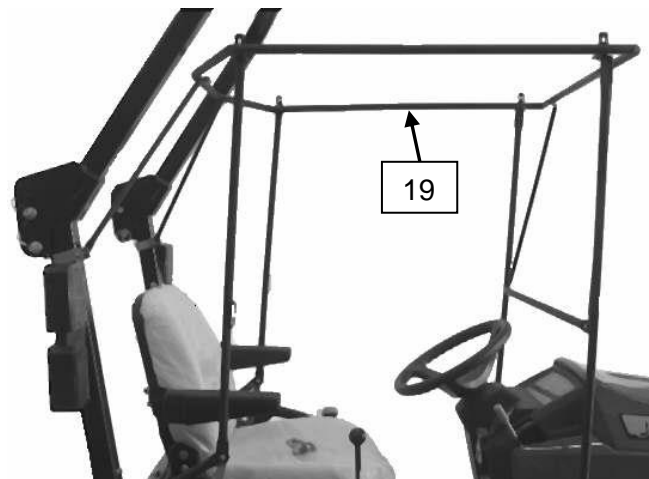
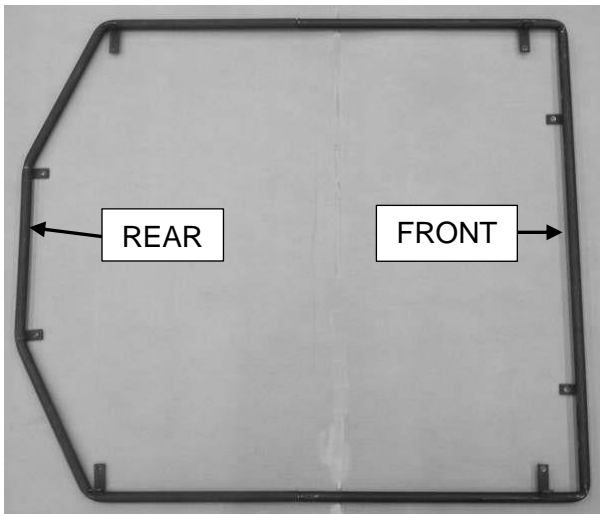

Figure 12

Step 13; See Figure 13:

Install Edge Trim onto Plastic Top.

A. Push the edge trim into the notches as shown on the Plastic Top. Use a mallet or hammer to gently tap the trim in place.

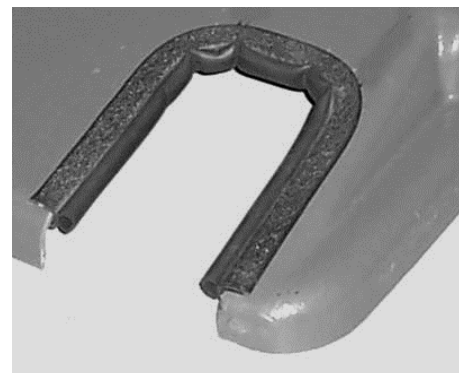

Figure 13

Step 14; See Figure 14:

Install the Plastic Top and Doors for frame / door alignment.

A. Make sure that the ROPS is pinned in the up position. Set the Top in place on the Top frame. Align the Bolt holes but **do not insert bolts at this time.**

B. Follow the instructions in the Door Hardware Package to install the Door Bottoms and the Door Latches.

C. Install, close and latch both Doors.

D. Tighten ALL bolts from previous steps at this time.

E. Remove the doors by lifting the door up and out of the bottom hinge then lowering out of the top hinge. Remove the Plastic Top.



Figure 14

Step 15; See Figure 15 & 15A:

Install Windshield (20) and Front Panel Vinyl (21).

A. Place the Windshield and Front Panel Vinyl face up on a clean flat surface. Press the Velcro® together so that both edges are equal

B. Lay the rod sewn into the top of the windshield over the top frame. Press the Velcro® together around the corners of the top frame.

C. Secure the ties to the cross bar and Press the Velcro® together around the posts.

D. Hook the springs under the motor mounts or where needed.

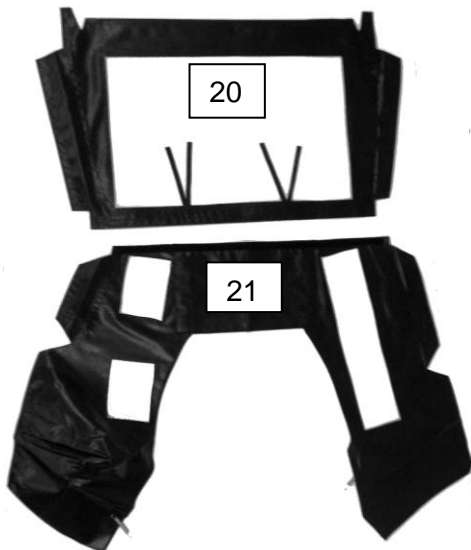

Figure 15 A

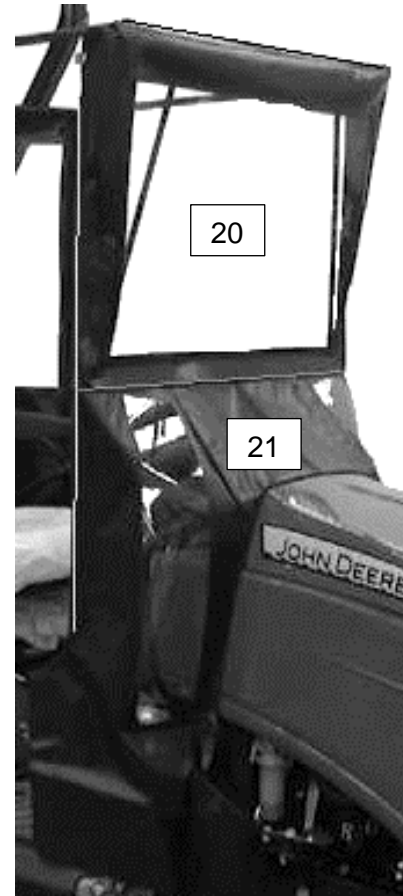

Figure 15

Step 16; See Figure 16 & 16A:

Install Rear Curtain (22).

- A.** Open the 2" Velcro® strips and set the Rear Curtain over the ROPS Clamps and ROPS Braces.
- B.** Press the Velcro® together around the top frame at the back and corners.
- C.** Press the Velcro® together around the Rear Posts, Rear Brackets and Vinyl Stays.
- D.** Place a notched plastic protector over the bent ends of each rear post.
- E.** Place the other plastic protectors over the bent ends of each ROPS Bracket.
- F.** Place the pieces of Foam Pad over the Top frame as indicated.

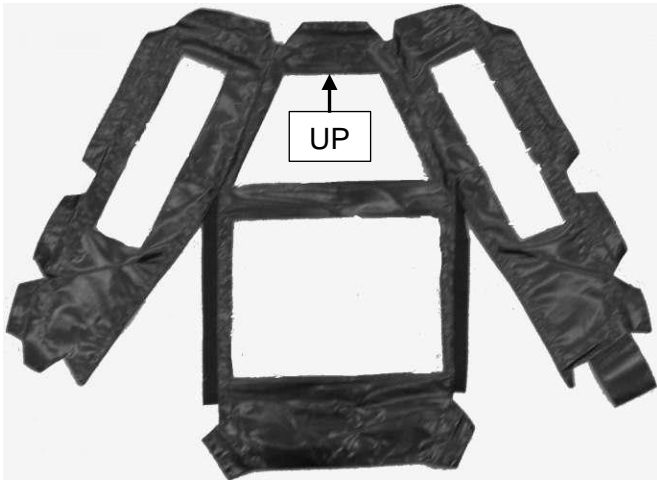

Figure 16A

Step 17; See Figure 17:

Install Doors and Top (27).

- A.** Make sure that the rod sewn into the windshield is lying over the top frame. Place the top over the top frame.
- B.** Install doors and connect the Velcro® strips on the lower door & front panel.
- C.** Place four 1/4" flat washers over each of four bolts. Insert bolts inwards, add locknuts and tighten.

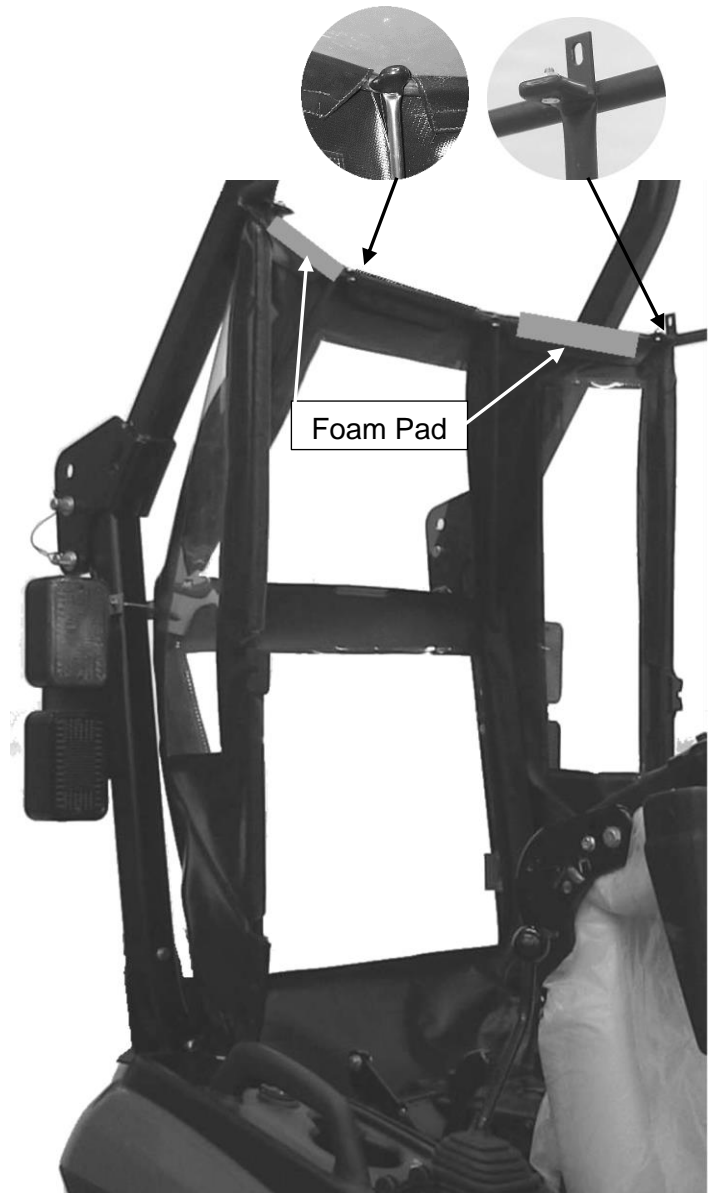

Figure 16



Figure 17



Optional Cab Accessories:

- #10120 Safety Glass Windshield**
- #10122 Electric Wiper**
- # 9855 Flashing Amber Caution Light**
- #11133 Rear View Mirror, R or L Mount**
- #11560 Work Light Kit**

For Replacement Parts and Accessories Contact:

Original Tractor Cab Co., Inc.
P.O. Box 97 6849 W. Front St.
Arlington, IN 46104
Phone 765-663-2214
Fax 765-663-2101
Email Sales@originalcab.com

Visit us on the web to see our other products.

www.originalcab.com

Cabs for Lawn Tractors, Garden Tractors, Compact Tractors, Snow Blowers, Utility Vehicles

Sunshades for Tractors, Mowers, & Utility Vehicles